

WELSEAL[®] 12'' LETTERBOX

FEATURES

- * FRAME AVAILABLE IN BLACK OR WHITE.
- * EXTERNAL WEATHER SEAL (INTERNAL DRAUGHT SEAL)
- * VARIABLE FLAP FINISHES
- * 2 STANDARD SLEEVE SETS AVAILABLE
- * NEOPRENE BACKSEAL AVAILABLE TO SEAL OFF EXTERNAL FRAME TO DOOR TO INCREASE WEATHERING PERFORMANCE.

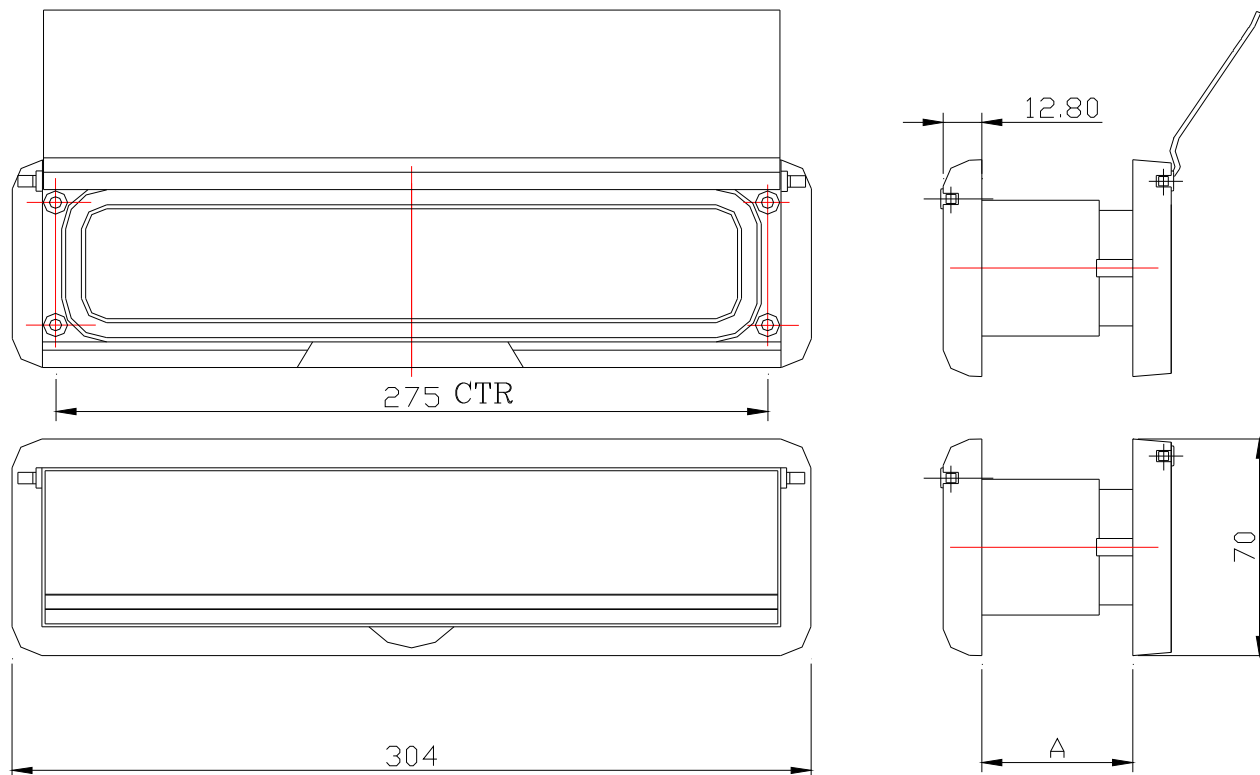

NOMINAL APPERTURE 254mm x 38mm
SLEEVE SET 'A' = 40/40
20/20

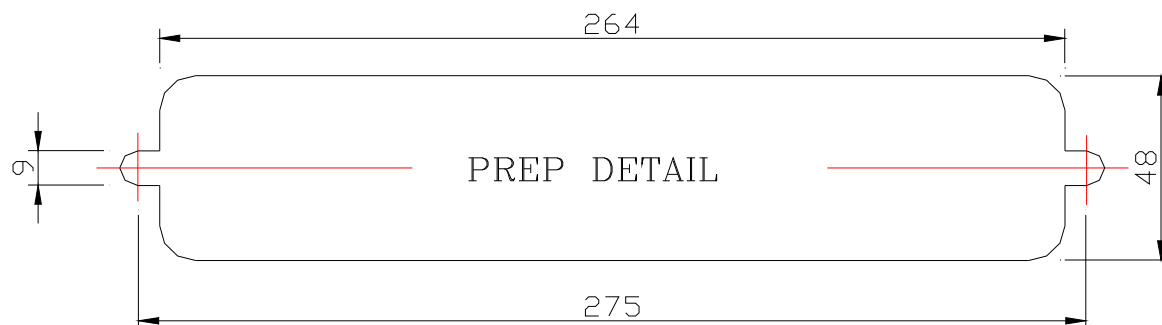

THE MANUFACTURERS RESERVE THE RIGHT TO MODIFY PRODUCT SIZE OR FEATURES WITHOUT PRIOR NOTICE



PADDOCK FABRICATIONS LTD
FRYERS ROAD
BLOXWICH, WALSALL
WEST MIDLANDS'
WS2 7NF

Tele. 01922-711722

Fax. 01922-476021

E-mail: sales@paddockfabrications.co.uk

Website: www.paddockfabrications.co.uk

Website: www.willengltd.com